

LM2736 Evaluation Board

National Semiconductor
Application Note 1418
Maurice Eaglin
October 2005



Introduction

The LM2736 demo board is configured to convert 5V input to 1.5V output at 750 mA load current using the LM2736X 1.6 MHz or the LM2736Y 550 kHz step down DC-DC regulator. The tiny low profile thin SOT23 package allows the demo board to be manufactured using less than 1 square inch of a 4-layer printed circuit board.

The circuit is configured with the boost diode connected to V_{IN} , and according to the datasheet, V_{IN} must not exceed the maximum operating limit of $5.5V + V_{ID2}$ using this configuration. This will ensure that the voltage between the Boost and SW pins, $V_{BOOST} - V_{SW}$, does not exceed 5.5V for proper operation. Please see the LM2736 datasheet for more information regarding this requirement.

A bill of materials below describes the parts used on this demo board. A schematic and layout have also been in-

cluded below along with measured performance characteristics. The schematics at the end of this document show how to re-configure this demo board for various input and output conditions as discussed in the LM2736 datasheet. Short or leave open the indicated connection as indicated in the schematics. The above restrictions for the input voltage are valid only for the demo board as shipped with the demo board schematic below.

Operating Conditions

$V_{IN} = 5V$
 $V_O = 1.5V$
 $I_O = 750\text{ mA}$

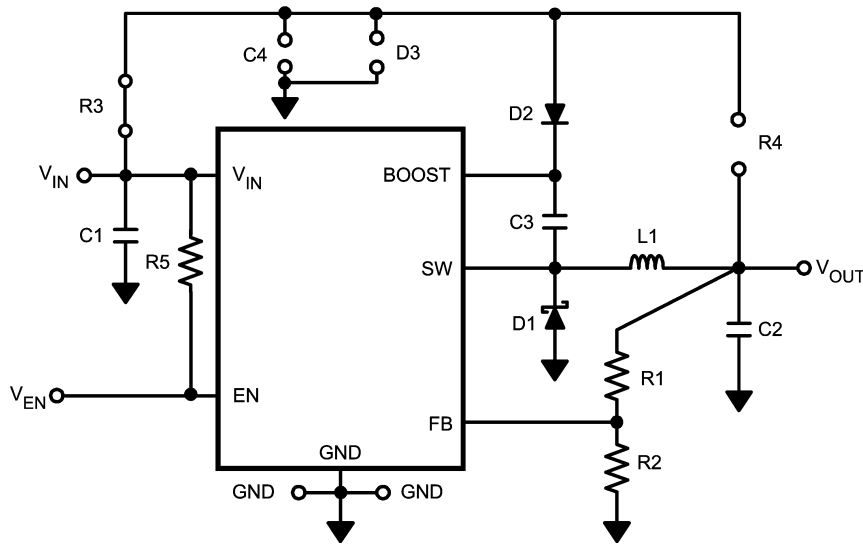

LM2736 Demo Board Schematic

20170901

Operating Conditions (Continued)

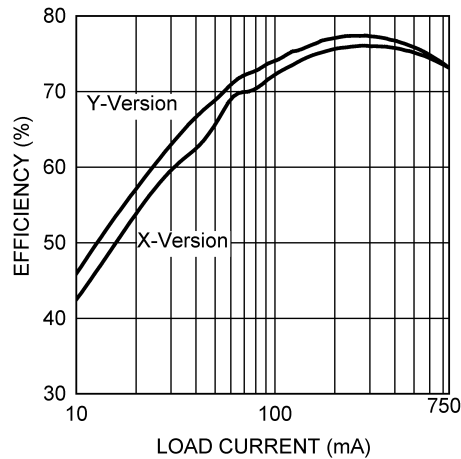

20170902

Efficiency vs Load Current

Bill of Materials X-Version

Part ID	Part Value	Manufacturer	Part Number	Package Type
C1, Input Cap	4.7 μ F, 10V, X5R	Murata	GRM42-6X5R475K10	1206
C2, Output Cap	10 μ F, 6.3V, X5R	Murata	GRM42-6X5R106K6.3	1206
C3, Boost Cap	0.01 μ F	Vishay	VJ1206Y103KXXA	1206
D2, Boost Diode	1V _f @ 50 mA Diode	Diodes, Inc.	1N4148W	SOD-123
R2	10 k Ω , 1%	Vishay	CRCW12061002F	1206
U1	750 mA Buck Regulator	National Semiconductor	LM2736X	Thin SOT23-6
D1, Catch Diode	0.34V _f Schottky 1A, 20V _R	International Rectifier	MBRA120	SMA
L1	4.7 μ H, 1.6A, 28 m Ω	TDK	SLF6028T-4R7M1R6	6028
R1	2 k Ω , 1%	Vishay	CRCW12062001F	1206
R3	0 Ω	Vishay	CRCW12060000F	1206
R5	50 k Ω , 1%	Vishay	CRCW08055002F	0805
D3, C4, R4	Open			

Bill of Materials Y-Version

Part ID	Part Value	Manufacturer	Part Number	Package Type
C1, Input Cap	10 μ F, 10V, X5R	Murata	GRM42-6X5R106K10	1206
C2, Output Cap	10 μ F, 6.3V, X5R	Murata	GRM42-6X5R106K6.3	1206
C3, Boost Cap	0.01 μ F	Vishay	VJ1206Y103KXXA	1206
D2, Boost Diode	1V _f @ 50 mA Diode	Diodes, Inc.	1N4148W	SOD-123
R2	10 k Ω , 1%	Vishay	CRCW12061002F	1206
U1	750 mA Buck Regulator	National Semiconductor	LM2736Y	Thin SOT23-6
D1, Catch Diode	0.34V _f Schottky 1A, 20V _R	International Rectifier	MBRA120	SMA
L1	10 μ H, 1.3A, 53 m Ω	TDK	SLF6028T-100M1R3	6028
R1	2 k Ω , 1%	Vishay	CRCW12062001F	1206
R3	0 Ω	Vishay	CRCW12060000F	1206
R5	50 k Ω , 1%	Vishay	CRCW08055002F	0805
D3, C4, R4	Open			

PCB Layout

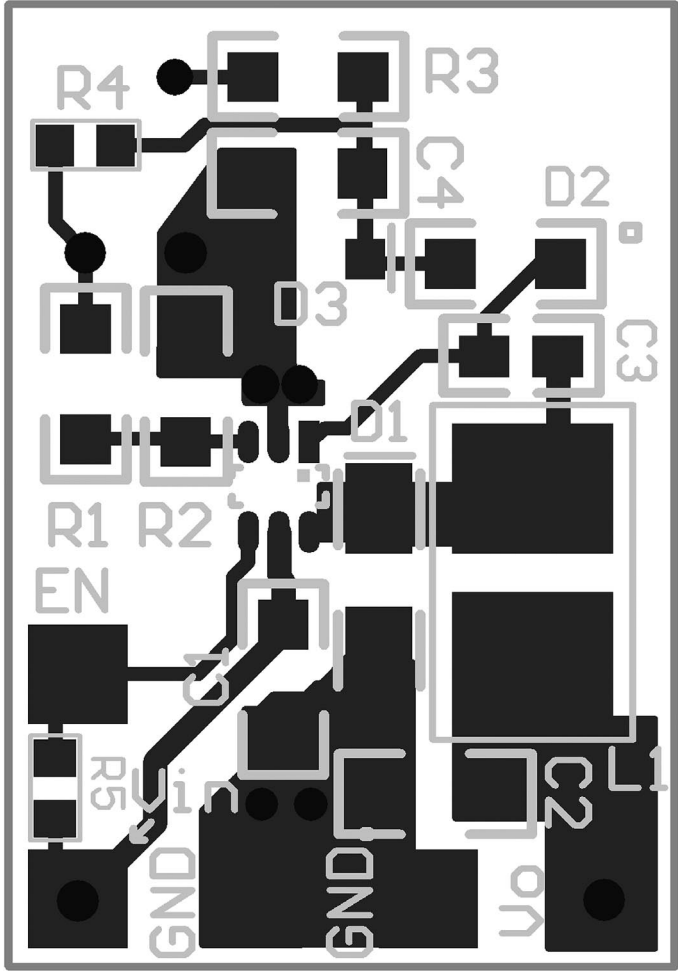

20170903

Top Layer

PCB Layout (Continued)

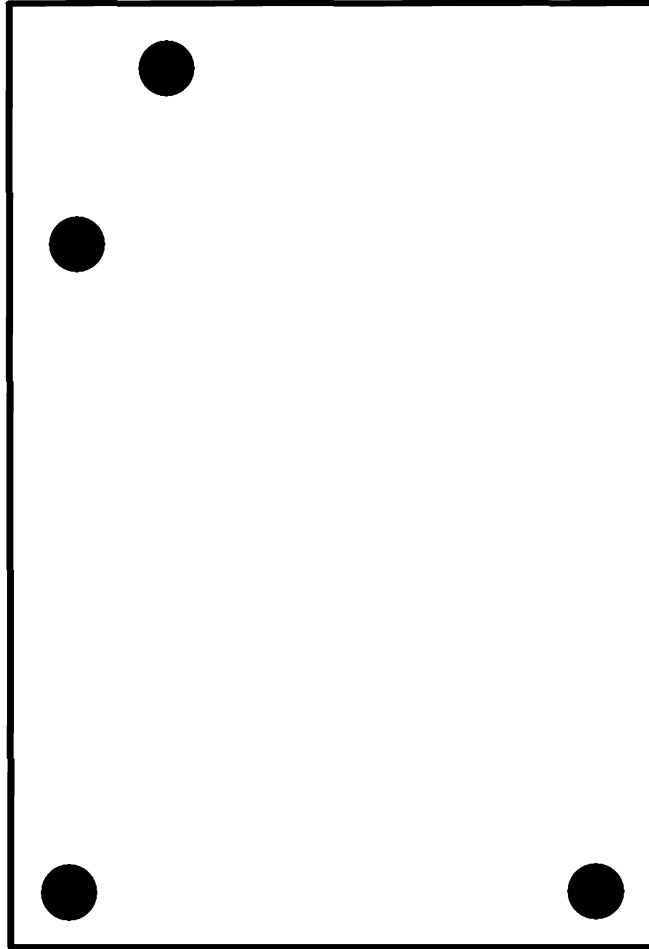

Internal Plane 1 (GND)

20170904

PCB Layout (Continued)

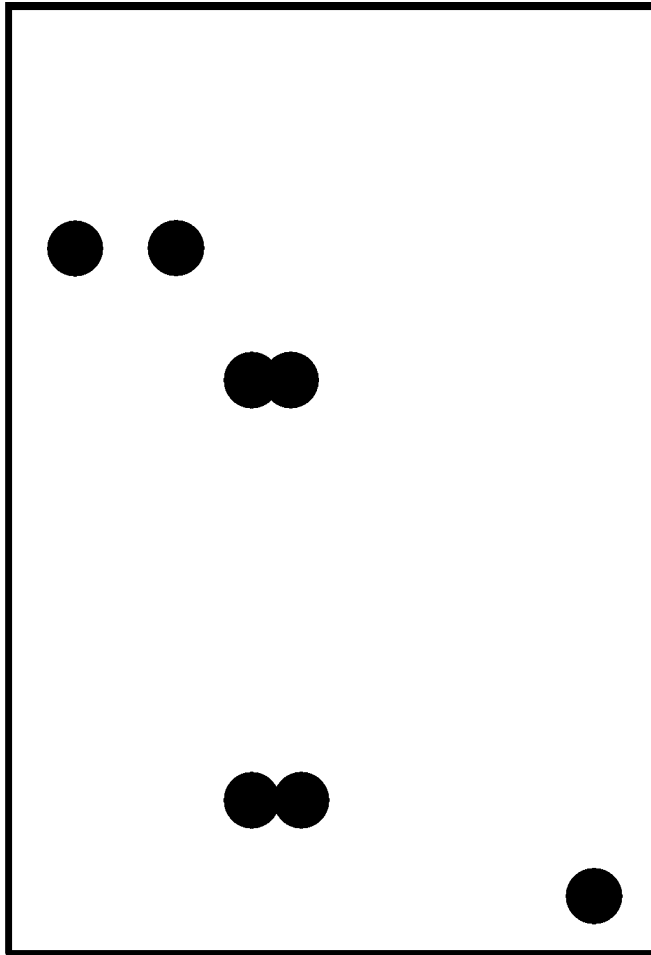

20170905

Internal Plane 2 (V_{IN})

PCB Layout (Continued)

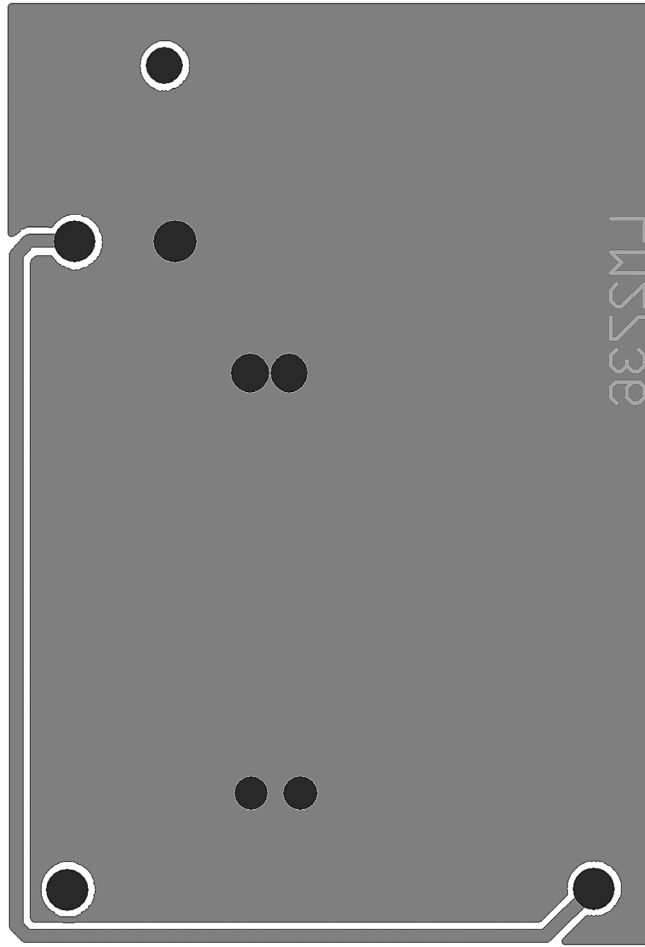

LMS532

20170906

Bottom Layer

Additional Circuit Configuration Schematics

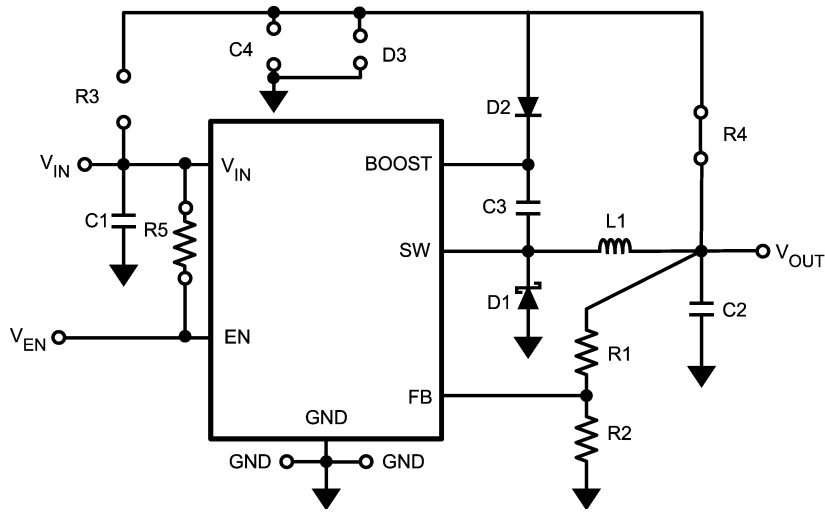

20170907

V_{BOOST} Derived from V_{OUT}

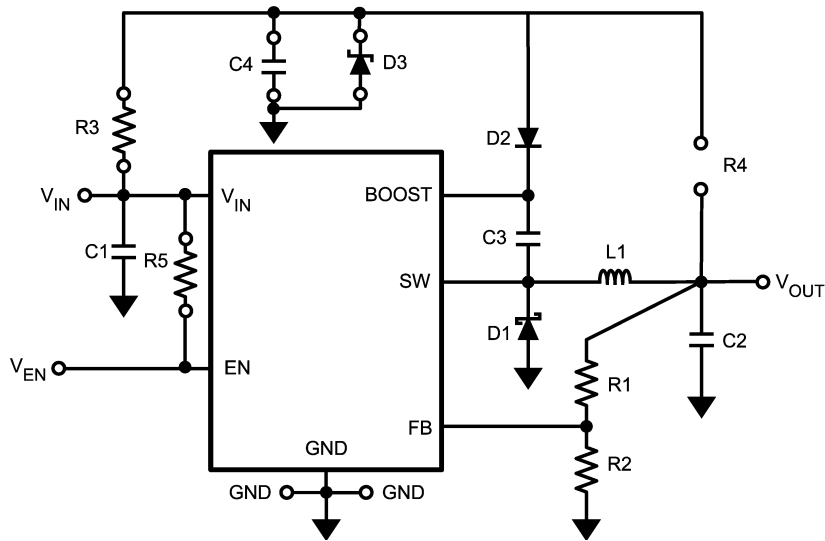

20170908

V_{BOOST} Derived from V_{SHUNT}

Additional Circuit Configuration Schematics (Continued)

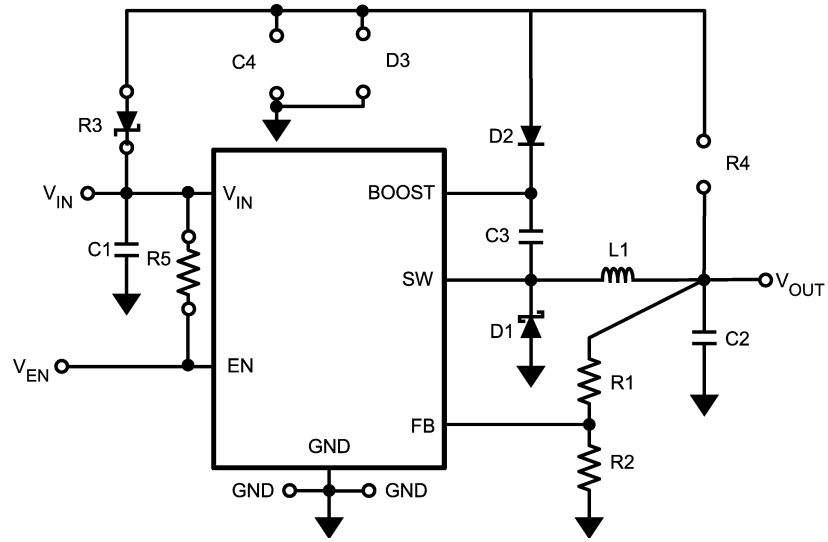

20170909

V_{BOOST} Derived from Series Zener Diode (V_{IN})

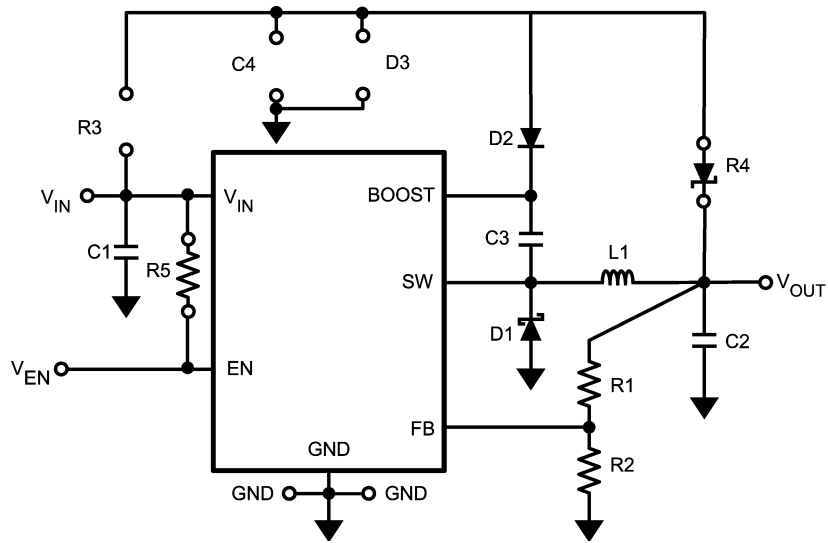

20170910

V_{BOOST} Derived from Series Zener Diode (V_{OUT})

Notes

National does not assume any responsibility for use of any circuitry described, no circuit patent licenses are implied and National reserves the right at any time without notice to change said circuitry and specifications.

For the most current product information visit us at www.national.com.

LIFE SUPPORT POLICY

NATIONAL'S PRODUCTS ARE NOT AUTHORIZED FOR USE AS CRITICAL COMPONENTS IN LIFE SUPPORT DEVICES OR SYSTEMS WITHOUT THE EXPRESS WRITTEN APPROVAL OF THE PRESIDENT AND GENERAL COUNSEL OF NATIONAL SEMICONDUCTOR CORPORATION. As used herein:

1. Life support devices or systems are devices or systems which, (a) are intended for surgical implant into the body, or (b) support or sustain life, and whose failure to perform when properly used in accordance with instructions for use provided in the labeling, can be reasonably expected to result in a significant injury to the user.
2. A critical component is any component of a life support device or system whose failure to perform can be reasonably expected to cause the failure of the life support device or system, or to affect its safety or effectiveness.

BANNED SUBSTANCE COMPLIANCE

National Semiconductor manufactures products and uses packing materials that meet the provisions of the Customer Products Stewardship Specification (CSP-9-111C2) and the Banned Substances and Materials of Interest Specification (CSP-9-111S2) and contain no "Banned Substances" as defined in CSP-9-111S2.

Leadfree products are RoHS compliant.



National Semiconductor
Americas Customer
Support Center
Email: new.feedback@nsc.com
Tel: 1-800-272-9959

www.national.com

National Semiconductor
Europe Customer Support Center
Fax: +49 (0) 180-530 85 86
Email: europe.support@nsc.com
Deutsch Tel: +49 (0) 69 9508 6208
English Tel: +44 (0) 870 24 0 2171
Français Tel: +33 (0) 1 41 91 8790

National Semiconductor
Asia Pacific Customer
Support Center
Email: ap.support@nsc.com

National Semiconductor
Japan Customer Support Center
Fax: 81-3-5639-7507
Email: jpn.feedback@nsc.com
Tel: 81-3-5639-7560